

Can *Phyllanthus Emblica* (Amloki) Alleviate Colchicine Induced Memory Impairment? An Experimental Study in Male Long-Evans Rats

Fhamida Akter¹, Mahatab Bin Mostafa², Puspita Basak³, Rokhsana Binte Amin⁴

Abstract:

Background: Memory is a crucial component of our daily lives. Thus, its deterioration should be managed. In this regard, pharmacological treatments have become less favourable due to their prolonged duration and numerous adverse effects. *Phyllanthus emblica* (PE) may be a suitable substitute because of its diverse biological functions, cost efficiency, lower toxicity and easy accessibility. **Objective:** To evaluate the alleviative role of ethanolic extract of *Phyllanthus emblica* (EEPE) fruit on memory. **Methods:** This study was performed at the KM Farid uddin Animal Research Laboratory, Department of Physiology, BMU, involving 24 male Long-Evans rats (8±2 weeks; 225±75 gm). On the basis of treatments, all rats (6 rats/group) were grouped into normal control (NC), sham control (SC), colchicine control (ColC), post-colchicine *Phyllanthus emblica* treatment (Post PE Exp). A single dose of colchicine (15 µg) caused memory impairment and Morris water maze (MWM) was used to test for learning and memory. **Results:** Here, in Reference memory performance colchicine caused significantly higher mean escape latency (EL) (p≤0.001) in acquisition phase and average EL of 5th and 6th acquisition days (p≤0.01) as well

as significantly (p≤0.001) lower target crossings (TC) and time spent in target (TT) in ColC rats in comparison to those SC rats. In contrast, significantly lower mean EL (p≤0.001) in acquisition phase and average EL of 5th and 6th acquisition days (p≤0.05) along with significantly higher TC and TT (p≤0.001) were found in Post PE Exp rats, in comparison to those of ColC rats. In working memory test, colchicine also caused significantly higher mean EL (p≤0.001) in training and test phase in ColC rats, in comparison to those SC rats. However, our experimental (Post PE Exp) rats showed significantly (p≤0.001) lower mean EL when compared to those of ColC rats. Moreover, when we compared all these memory variables between our experimental and NC rats, they were found statistically non-significant. **Conclusion:** The study revealed that *Phyllanthus emblica* (Amloki) may be an encouraging therapeutic option for mitigating the neurotoxicity associated with colchicine; however, more studies are needed to define the exact mechanism through which PE functions.

Key words: Colchicine, Hippocampus, Memory impairment, *Phyllanthus emblica* (PE), Morris water maze.

J Com Med Col Teachers' Asso Jan 2026;30(1): 09-15

1. Dr Fhamida Akter
Assistant Professor, Department of Physiology
Eastern Medical College, Cumilla
2. Dr Mahatab Bin Mostafa
Register, Department of ENT and HNS
Dhaka Community Medical College,
Baro Moghbazar, Dhaka
3. Dr Puspita Basak
Assistant Professor, Department of Physiology
Monno Medical College, Manikganj
4. Dr Rokhsana Binte Amin
Lecturer, Department of Pathology
Shaheed Ziaur Rahman Medical College, Bogura

Address of Correspondence:

Dr Fhamida Akter
Assistant Professor, Department of Physiology
Eastern Medical College, Cumilla
E-mail: shompadjmc@gmail.com; Cell: +8801717032135

Introduction:

Medicinal plants have been acknowledged and utilized for disease treatment since ancient times. People in developing and low-income countries rely on these plants for addressing various minor and major health conditions. In several developing nations, including Bangladesh, about 80% of the population depends on traditional medicine. The practice of traditional medicine is not limited to developing countries; it is also present in various industrialized nations. Medicinal plants are the most significant source of natural nootropics. *Phyllanthus emblica* (PE), commonly known as amloki, is part of the Euphorbiaceae family. Different clinical studies have reported that PE has hepatoprotective¹, antitussive², anti-pyretic³, analgesic³, antidiabetic⁴, anti-malignant⁵, anti-malarial⁶, anti-inflammatory⁷, hypolipidemic⁸, nephroprotective⁹ as well as antimicrobial¹⁰ properties.

Memory is the process of encoding, storing, and retrieving learned knowledge¹¹. Memory impairment is a type of unusual forgetfulness that differs from normal age-related forgetfulness, and it plays a significant role in dementia, which affects over 55 million people worldwide. Symptoms of dementia include forgetting recent events, misplacing items, getting lost, feeling confused in familiar places, losing

track of time, having trouble making decisions, struggling to find words and misjudging distances¹². Factors like physical inactivity, a sedentary lifestyle, and stress are linked to memory impairment. Other conditions, such as brain trauma, stroke, infections, tumors and neurodegenerative disorders like Alzheimer's and Parkinson's diseases, also contribute to this problem¹³.

Memory depends on the hippocampus which is the most medial portion of the temporal lobe cortex. The Neurodegeneration of this hippocampus can result in memory impairment. Colchicine, an alkaloid drug, destroys microtubular assembly, decreases axoplasmic transport¹⁴, increases free radical generation and oxidative stress¹⁵ followed by hippocampal neurodegeneration resulting in memory impairment in rat.

Nowadays, the treatment plan for memory impairment consists of a variety of drugs, including galantamine, rivastigmine, donepezil, and others¹⁶. However, a wide range of harmful outcomes is associated with the regular consumption of these medications, which hinders their utility in the management of memory impairment. As far as we searched, only a few researches have shown the role of PE on prevention of memory impairment, but no study was found to explore this PE's effect on alleviation of these morbidities. Based on this background, the present study has been designed to evaluate the effects of ethanolic extract of PE (EEPE) on memory performance after intrahippocampal colchicine induced memory impairment in male Long-Evans rats.

Methods:

Animals

All experiments were conducted with 24 healthy adult male Long-Evans rats, each weighing approximately 225±75 gm and aged 8±2 weeks, sourced from the central animal house of Bangladesh Medical University (BMU) in Dhaka, Bangladesh. The rats were housed six per cage and maintained under standard environmental conditions, with temperatures ranging from 27 to 28°C and a half-day light and dark cycle. Proper administration of standard laboratory food and water was ensured. The experimental protocol received approval from the Institutional Review Board (Registration No: 4469) of the University, and the study was carried out in the KM Farid Uddin animal laboratory within the Department of Physiology at Bangladesh Medical University (BMU), Dhaka, Bangladesh.

Extract preparation

In August 2023, fresh leaves of PE were collected from Hajiganj upazila, located in the Chandpur district of Bangladesh. An expert taxonomist from the Bangladesh National Herbarium in Mirpur, Dhaka, Bangladesh

conducted the identification, and a voucher specimen (Accession number: DACB 90617) has been stored in the herbarium for future reference. According to Uddin et al. (2016)¹⁷, 5 kg of PE fruits were collected, washed, and shade dried for 30 minutes. After the seeds were removed, the fruits underwent an additional drying process for 7 days using irregular sun drying. The dried fruits were then ground into a powder and stored in an airtight container for extraction. Approximately 500 grams of powder (from 5 kg) was soaked in 2.5 liters of 98% ethanol at room temperature (24-27° C) for 7 days with frequent shaking. The mixture was filtered through cotton and subsequently through Whatman (Grade no.1) filter paper, concentrated, and dried at 50°C using a rotatory evaporator, after which the ethanolic extract was stored at 4°C for future use.

Drugs and chemicals

Normal saline (Opso Saline Ltd, Bangladesh), gentamicin (Incepta Pharmaceuticals Ltd, Bangladesh), thiopental sodium (Gonosasthaya Pharmaceuticals Ltd), di-ethyl ether (MERCK, Germany) and Ethanol (MERCK, Germany) were purchased from local market. Colchicine was obtained from Incepta Pharmaceuticals Ltd, Bangladesh.

Study design:

Rats were divided randomly into 4 groups as follows (6rats/group):

NC group: Healthy group (No stereotaxic surgery and PE treatment)

SC group: Intrahippocampal infusion of 1 µl normal saline by stereotaxic surgery and no PE.

ColC group: Single dose colchicine (15 µg in 1 µl normal saline) was infused in hippocampus by stereotaxic surgery without any PE treatment.

Post PE Exp group: Ethanolic extract of *Phyllanthus emblica* (EEPE) was administered intraperitoneally (i.p) at a dose of 700 mg/kg for 7days after hippocampal infusion of colchicine(15µg in 1µl normal saline) by stereotaxic surgery.

Intra Hippocampal colchicine infusion by stereotaxic surgery

In prior studies^{18,19,20}, colchicine was delivered to rats in the hippocampus via stereotaxic surgery. Before the surgical procedure, the rats were fasted overnight but allowed to drink water. On the day of surgery, they were anesthetized with thiopental sodium (45 mg/kg, i.p) and secured in a stereotaxic apparatus. After making a scalp incision and retracting the skin, 15 µg of colchicine in 1 µl of normal saline was injected into each hippocampus using a Hamilton micro syringe, administered very slowly over a duration of 1 minute. The micro syringe was maintained in position for the next minute (60 seconds) before being gently withdrawn. The infusion coordinates were: -3.6 mm anterior-posterior, ± 2

mm lateral-medial and -3.4 mm dorso-ventral relative to bregma. Control subjects received a vehicle injection. The scalp was then closed with sutures. Immediately following the surgical procedure, the rat was placed in a post-operative cotton bed for 2 days, with all aseptic precautions and care taken for feeding until it recovered from the surgical stress. Gentamycin (5 mg/kg, i.p) was given post-operatively to prevent sepsis.

Morris Water Maze (MWM) test

Apparatus

The MWM test is designed to evaluate reference and working memory by utilizing a large circular pool that is 150 cm in diameter and 50 cm high, filled with water^{21,22}. To prevent visual cues, the pool's walls and platform are painted black, and it is located in a room that features additional maze cues to aid in the orientation of the rats. The pool is segmented into four quadrants, which include eight starting points: north (N), south (S), east (E), west (W), north-east (NE), north-west (NW), south-east (SE) and south-west (SW). In the center of the NE quadrant, there is a hidden platform that measures 15 cm in diameter and 28 cm in height, positioned 2 cm below the water surface to keep it hidden from view. Two testing methods are utilized to assess memory skills, and the working plans for four groups of rats are depicted in figure 1.

Reference memory test

As represented in figure 1, the rats swam for 3 minutes without a platform for 3 consecutive days to undergo instrumental acclimatization and the habituation phase of the Reference memory version. In the acquisition phase that followed, the rats were subjected to four trials each day over 6 consecutive days, remaining in a fixed position in the NE quadrant. Each trial involved releasing the rats from different starting points in a unique sequence each day, providing them with 60 seconds to locate and climb onto the platform. A 50 seconds intertrial time (20 seconds on the platform and 30 seconds for self-drying) was allowed. The latency to find the platform, known as the mean escape latency (EL) the time from the moment a rat entered the water until it reached the platform-was recorded using a stopwatch to evaluate the learning ability of the rats. Each rat underwent four similar trials over six consecutive days. In the first trial of each day, the rats reached the platform by chance, which constituted the information stage, while subsequent trials required matching to the novel position each day, as the platform remained fixed for six days. The average EL for the 5th and 6th acquisition days was measured to assess memory consolidation. Approximately 24 hours after the last trial on day 6, the platform was removed from the pool, and a final spatial probe trial was conducted to assess learning strength and retrieval. In this probe trial, the rats were allowed to swim freely for 60 seconds, during which target crossings

(TC) the number of times the rats crossed the quadrant of the MWM within 60 seconds from where the platform was removed and time spent in the target (TT) the time spent in the quadrant from which the platform was removed within 60 seconds - were measured²³.

Working memory test

As shown in figure 1, about 48 hours after the probe trial, the working memory version of the test was conducted using a testing paradigm adapted from Sarihi et al. (2000)²¹. Here, the 6 days acquisition phase of the reference memory test was regarded as the pre-training phase of the working memory assessment. Then, a training and a test phase was conducted over 4 consecutive days with 4 trials each day. Everyday, the platform position was changed but kept constant for the daily 4 trials. However, every rat was released from 4 different starting points in the 4 daily trials, all of which were distant from the platform position. On the first trial of each day, rats reached the platform by chance, which constituted the information stage, and the subsequent trials required matching to the novel position for that day as the platform was changed every day. The mean EL in the training and test phase was recorded as above to assess learning ability.

Statistical analysis:

Results were presented as mean ± SEM (Standard Error of Mean). Statistical analysis of the data was conducted through ANOVA, followed by the Bonferroni post hoc test in SPSS (version 25.0), considering $p \leq 0.05$ as statistically significant.

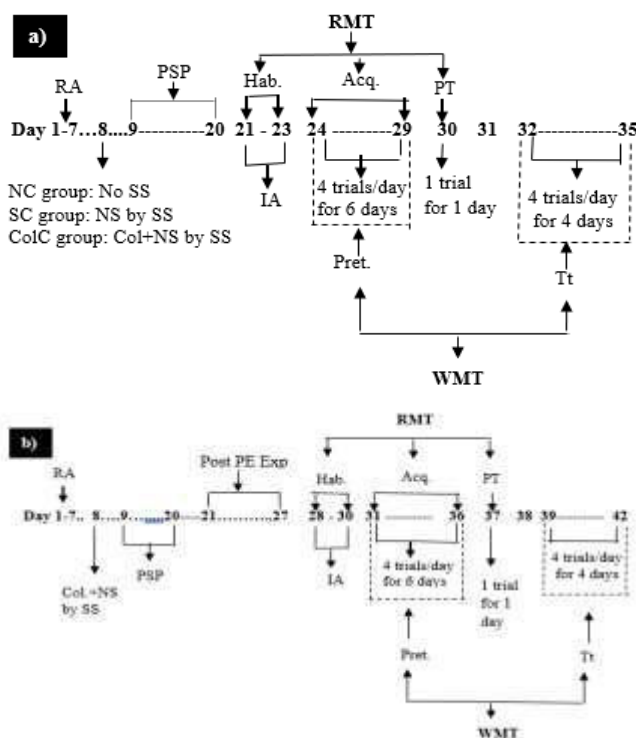

Figure-1: Experimental design for a) control rats (normal control; sham control; colchicine control) and b) experimental rats (Post PE Exp)

RMT: Reference memory test; WMT: Working memory test; RA=Room acclimatization; PSP=Post-surgical period; Hab.=Habituation; Acq.=Acquisition; PT=Probe trial; IA=Instrumental acclimatization; Pret.= Pretraining; Tt=Training and test; NS=Normal saline; SS=Stereotaxic surgery; Col.=Colchicine

Results:

Effect of EEPE on reference memory after memory impairment

As indicated in Table I, ColC rats exhibited a significantly ($p \leq 0.001$) higher mean escape latency (EL) across all acquisition days when compared to SC rats. Nevertheless, EEPE enhanced the learning performance of our rats, as shown by statistically significant ($p \leq 0.001$) differences in mean EL between our ColC and experimental (Post PE Exp) rats. Notably, the differences in this variable between Post PE Exp and NC rats were statistically non-significant on the final acquisition day. In Table I, it has been shown that the mean value of average escape latency (EL) on the 5th and 6th acquisition days was significantly ($p \leq 0.01$) higher in ColC rats in comparison to SC rats. Additionally, PE showed significantly ($p \leq 0.05$) lower average EL in experimental (Post PE Exp) rats than that of ColC rats. On the contrary, the differences of this variable between NC vs Post PE Exp rats were found statistically non-significant. In the study, ColC rats showed retrieval impairment, as evidenced by significantly ($p \leq 0.001$) lower TC and TT than those of SC rats. This PE carried out significantly ($p \leq 0.001$) higher TC and TT in experimental (Post PE Exp) rats than that of ColC rats. And, Statistical analysis revealed that the differences in these variables between NC vs Post PE Exp rats were not significant (Table II).

Table-I: Mean escape latency (EL, in seconds) and average escape latency (EL of 5th and 6th days, in seconds) in acquisition phase of Morris water maze test in different groups of rats

Mean EL of acquisition day	Groups			
	NC	SC	ColC	Post PE Exp
1 st	26.21±2.29	30.63±2.43	60.0±0.00***	44.00±1.67 ^{SSS/YYY}
2 nd	22.58±0.99	25.42±0.62	58.88±0.53***	40.63±1.21 ^{SSS/YYY}
3 rd	14.54±1.82	18.92±0.44	56.5±1.17***	36.58±1.66 ^{SSS/YYY}
4 th	13.08±1.71	17.5±0.76	53.92±0.66***	32.16±1.40 ^{SSS/YYY}
5 th	12.96±1.19	15.92±0.71	51.71±1.09***	29.96±1.83 ^{SSS/YYY}
6 th	12.21±0.96	13.33±0.35	49.46±1.99***	16.79±0.92 ^{SSS}
Average EL of 5 th and 6 th acquisition days	12.58±0.21	14.62±0.74	50.58±0.64**	23.38±3.80 ^S

Each day represents mean ± SEM of 4 trials of 6 rats in that day. Values in parenthesis indicate ranges. Statistical analysis was done by ANOVA (among groups) followed by

Bonferroni's post hoc test (between groups). * = SC vs ColC, \$ = ColC vs Post PE Exp, ¥ = NC vs Post PE Exp. In the interpretation of results, $p \leq 0.05$ was considered as significant. ***/\$\$\$/YYY = $p \leq 0.001$, **/\$\$/¥¥ = $p \leq 0.01$, */\$/¥ = $p \leq 0.05$.

Table-II: Target crossings (TC, in frequency/minute) and time spent in target (TT, in seconds/minute) in probe trial of Morris water maze test in different groups of rats

Variables in probe trial day	Groups			
	NC	SC	ColC	Post PE Exp
TC	8.00 ± 0.26	7.17 ± 0.27	1.66± 0.18***	6.83±0.31 ^{SSS}
TT	18.16 ± 0.48	16.17 ± 0.61	5.83± 0.67***	15.67±0.49 ^{SSS}

Each column symbolizes mean ± SEM for 6 rats. Values in parenthesis indicate ranges. Statistical analysis was done by ANOVA (among groups) followed by Bonferroni's post hoc test (between groups). * = SC vs ColC, \$ = ColC vs Post PE Exp. In the interpretation of results, $p \leq 0.05$ was considered as significant. ***/\$\$\$ = $p \leq 0.001$.

Effect of EEPE on working memory after memory impairment

In Table III, it was demonstrated that ColC rats exhibited a significantly ($p \leq 0.001$) higher mean EL compared to SC rats across all trials on all test days. Nevertheless, EEPE enhanced the learning performance of our rats, as indicated by statistically significant differences in mean EL between our ColC and experimental Post PE Exp ($p \leq 0.01$ in trial 1 and 2, $p \leq 0.001$ in trial 3 and 4) rats. Notably, the differences in this variable were statistically non-significant between NC and Post PE Exp in trial 4 across all test days.

Table-III: Mean escape latency (EL, in seconds) in training and test phase of Morris water maze test in different groups of rats

Mean EL in trial	Groups			
	NC	SC	ColC	Post PE Exp
1	20.75±0.59	22.13±1.84	41.13±1.34***	32±1.84 ^{SS/YY}
2	10.88±0.63	14.88±1.74	37.38±1.12***	26.5±2.60 ^{SS/YYY}
3	8.38±0.52	9.88±1.09	32.75±1.19***	22.375±1.28 ^{SSS/YYY}
4	7.75±0.52	10.38±1.25	27.63±1.14***	13±1.39 ^{SSS}

Trial 1 = mean ± SEM of 4 trial 1s of 6 rats in consecutive 4 days; Trial 2 = mean ± SEM of 4 trial 2s of 6 rats in consecutive 4 days; Trial 3 = mean ± SEM of 4 trial 3s of 6 rats in consecutive 4 days; Trial 4 = mean±SEM of 4 trial 4s of 6 rats in consecutive 4 days. Values in parenthesis indicate ranges. Statistical analysis was done by ANOVA (among groups) followed by Bonferroni's post hoc test (between groups). * = SC vs ColC, \$ = ColC vs Post PE Exp, ¥ = NC vs Post PE Exp. In the interpretation of results, $p \leq 0.05$ was considered as significant. **/¥¥/\$\$ = $p \leq 0.01$; ***/¥¥¥/\$\$\$ = $p \leq 0.001$.

Discussion:

Memory, specially the spatial memory, is among the most complex processes of the brain, necessary for the proper functioning of any living organism. Impairment of this memory can sufficiently hinder an individual's intellectual ability, thus interfering with their personal behaviors and social communications. Some animal studies conducted in the last decade have focused on the effect of PE supplementation before hippocampal damage in preventing spatial memory impairment^{24,17,25}. However, in the clinical settings, patients suffering from spatial memory impairment tend to seek medical advice after diagnosis. It emphasizes the significance of studying the influence of any intervention after spatial memory impairment. Notably, there is a lack of experimental research on the role of this fruit in alleviating hippocampal damage induced spatial memory impairment. These findings motivate us to investigate the potential effect of systemic EEPE administration in alleviating colchicine-induced memory impairment.

In this study, we conducted the Morris water maze (MWM) test to evaluate the effects of Ethanolic extract of *Phyllanthus emblica* (EEPE) on spatial learning and memory in a rat model that experienced memory impairment due to colchicine. In the Working memory version, the platform's location was altered daily, compelling the animals to acquire and apply new orientation cues within minutes during the testing session. Conversely, in the Reference memory task, the animals were trained for six days to memorize a fixed platform position, with the consolidation of learned memories affecting their final performance. Through the application of this memory test on the experimental model, the current study indicated that post-treatment with EEPE could improve memory impairment.

In this study, we administered 15 µg of colchicine to each hippocampus to induce memory impairment which might bind with microtubule binding protein (tubulin)²⁶, might depolymerized them²⁷, to cause decreased cellular growth, differentiation¹⁸ and hippocampal cholinergic neuronal damage²⁸. In addition, our intrahippocampal colchicine might cause increment of acetylcholinesterase (AChE) activity²⁹, which is an indirect evidence of cholinergic neuronal damage. In addition, our colchicine might increase the formation of beta amyloid protein (BAP) in hippocampus³⁰ by increasing the action of β secretase and γ secretase on amyloid precursor protein (APP). This BAP might accumulate extra cellularly forming A β plaques resulted in neuronal death. These A β plaques might also initiate an inflammatory response, along with direct action of colchicine on increment of COX-2 mRNA expression in hippocampus, resulted in neuroinflammation by COX-2, PGE₂ and proinflammatory cytokines (TNF- α , IL-1 β)³¹. This inflammatory cascades might cause hippocampal neuronal

damage and death. Here, both reference and working memory deficit was occurred in our memory impaired rats, as evidenced by lower learning ability, consolidation, retrieval ability in comparison to those of normal and sham control groups of rats.

However, PE improved both reference and working memory impairment as evidenced by improved learning ability, consolidation and retrieval ability of our experimental (Post treated) rats in comparison to those of memory disabled rats. Similar findings were observed by researchers in abroad in two animal models for reference memory impairment after pretreated PE^{24,32}. In our study, intraperitoneal PE after memory impairment might improve the condition by decreasing production of A β plaques through the suppression of APP breakdown by β and γ secretases²⁴. Moreover, our PE might reduce release of proinflammatory cytokines (TNF- α , IL-1 β) in hippocampus and reduce neuroinflammation and neuronal death²⁵.

As a whole, experimental rats (Post PE Exp) showed almost similar reference and working memory performances when compared to those of normal rats. From these findings, we proposed that our 7 days administration of EEPE could alleviate almost all the aspects of memory disability near to normal.

Conclusion:

Phyllanthus emblica (Amlaki) can alleviate colchicine induced memory impairment in male Long-Evans rats. Therefore, this fruit extract may be advantageous in the management of various cognitive disorders, dementia, and neurodegenerative diseases, particularly Alzheimer's disease. Further extensive research is needed before human application.

Conflict of interest: None

Acknowledgement:

The authors wish to express their gratitude to Bangladesh Medical University (BMU) for partially funding this research through a grant. We would also like to extend our appreciation to Dr. Birendra Nath Mallick, Professor and Director of the Amity Institute of Neuropsychology and Neurosciences in Gautam Budh Nagar, Uttar Pradesh, India, for his valuable suggestions and assistance in the proper execution of stereotaxic surgery. Additionally, we would like to thank Incepta Pharmaceuticals Ltd, Bangladesh, for supplying us with colchicine powder.

References:

1. Jose JK and Kuttan R. Hepatoprotective activity of *Embllica officinalis* and Chyavanaprash. J Ethnopharmacol 2000; 72(1-2):135-140. doi.org/10.1016/S0378-8741(00)00219-1.

2. Nosál'ova G, Mokry J, and Hassan KT. Antitussive activity of the fruit extract of *Emblica officinalis* Gaertn.(Euphorbiaceae). *Int J Phytomedicine* 2003; 10 (6-7):583-589.doi.org/10.1078/094471103322331872.
3. Perianayagam JB, Sharma SK, Joseph A, Christina AJM. Evaluation of anti-pyretic and analgesic activity of *Emblica officinalis* Gaertn. *J Ethnopharmacol* 2004; 95(1): 83-85. doi:10.1016/j.jep.2004.06.020.
4. Fatima N, Hafizur RM, Hameed A, Ahmed S, Nisar M, Kabir N. Ellagic acid in *Emblica officinalis* exerts anti-diabetic activity through the action on β -cells of pancreas. *Eur J Nutr* 2015; 56(2):591-601. doi: 10.1007/s00394-015-1103-y
5. Shynu M, Gupta KP, Saini M. Antineoplastic potential of medicinal plants. *Recent Pat Biotechnol* 2011; 5(2):85-94. doi: 10.2174/187220811796365662
6. Pinmai K, Hiriotte W, Soonthorncharenonn N, Jongsakul K, Sireeratawong S, Tor-Udom S. In vitro and in vivo antiplasmodial activity and cytotoxicity of water extracts of *Phyllanthus emblica*, *Terminalia chebula*, and *Terminalia bellerica*. *J Med Assoc Thai* 2011; 93(12):120-126. PMID: 21294406
7. Golechha M, Sarangal V, Ojha S, Bhatia J, Aryal DS. Anti-inflammatory effect of *Emblica officinalis* in rodent models of acute and chronic inflammation: involvement of possible mechanisms. *J Inflamm* 2014; 2014:178408. doi: 10.1155/2014/178408
8. Santoshkumar J, Manjunath S, Pranavakumar MS. A study of anti-hyperlipidemia, hypolipidemic and anti-atherogenic activity of fruit of *Emblica officinalis* (Amla) in high fat fed Albino rats. *Int J Med Res Health Sci* 2013; 2(1):70-77.
9. Malik S, Suchall K, Bhatia J, Khan SI, Vasisth S, Tomar A, Goyal S, Kumar R, Aryal DS, Ojha SK. Therapeutic potential and molecular mechanisms of *Emblica officinalis* Gaertn in countering nephrotoxicity in rats induced by the chemotherapeutic agent cisplatin. *Front Pharmacol* 2016; 7:350. doi: 10.3389/fphar. 2016. 00350
10. Al-Gbouri NM, Hamzah AM. Evaluation of *Phyllanthus emblica* extract as antibacterial and antibiofilm against biofilm formation bacteria. *Iraqi J Agric Sci* 2018; 49(1):142-151. doi.org/10.36103/ijas. v49i1.217
11. Shohamy D, Schacter DL, Wagner AD (2021). Learning and memory. In: Kandel ER, Koester JD 1, Mack SH, Siegelbaum SA, editors. *Principles of neural science*. 6thed. USA: McGraw-Hill. p. 1291-1311.
12. World Health Organization, 2023. Dementia [Internet] [Cited on 15 may, 2023]. Available from: <https://www.who.int/news room/factsheets/detail/dementia>.
13. Gironi M, Bianchi A, Russo A, Alberoni M, Ceresa L, Angelini A, Cursano C, Mariani E, Nemni R, Kullmann C, Farina E. Oxidative imbalance in different neurodegenerative diseases with memory impairment. *Neurodegener Dis* 2011; 8(3):129-137. doi:10.1159 /000319452.
14. Crothers SD, McCluer RH. Effect of colchicine on the delayed appearance of labelled protein into synaptosomal soluble proteins. *J Neurochem* 1975; 24(2):209-214.doi:10.1111/j.1471-4159.1975.tb 11866.x
15. Yu Z, Cheng G, Hu B. Mechanism of colchicine impairment on learning and memory, and protective effect of CGP36742 in mice. *Brain Res* 1997; 750(1-2):53-58. doi: 10.1016/S0006-8993(96)011 58-4
16. Kavirajan H, Schneider LS. Efficacy and adverse effects of cholinesterase inhibitors and memantine in vascular dementia: a meta-analysis of randomized controlled trials. *Lancet neurol* 2007; 6(9):782-792. doi: 10.1016/S1474- 4422(07)70195-3
17. Uddin MS, Al Mamun A, Hossain MS, Akter F, Iqbal MA, Asaduzzaman M. Exploring the effect of *Phyllanthus emblica* L. on cognitive performance, brain antioxidant markers and acetylcholinesterase activity in rats: promising natural gift for the mitigation of Alzheimer's disease. *Ann.Neurosci* 2016; 23(4):21829. doi:org/10.1159/000449482.
18. Nakagawa Y., Nakamura S., Kaše Y., Noguchi T., Ishihara T. Colchicine lesions in the rat hippocampus mimic the alterations of several markers in Alzheimer's disease. *Brain Res*. 1987; 408(1-2):57-64.
19. Paxinos G., Watson C. The rat brain in stereotaxic coordinates. 6th ed. Paris. Armstredium: Elsevier. 2007. pXII,pXXIX
20. Kumar A., Dogra S., Prakash A. Protective effect of naringin, a citrus flavonoid, against colchicine-induced cognitive dysfunction and oxidative damage in rats. *J Med Food*. 2010; 13(4):976-984.
21. Sarihi A., Motamedi F., Naghdi N., Pour A.R. Lidocaine reversible inactivation of the median raphe nucleus has no effect on reference memory but enhances working memory versions of the Morris water maze task. *Behav Brain Res*. 2000; 114(1-2):1-9.
22. Topuz R.D., Gunduz O., Tastekin E., Karadag C.H. Effects of hippocampal histone acetylation and HDAC inhibition on spatial learning and memory in the Morris water maze in rats. *Fundam Clin Pharmacol*. 2020; 34(2):222-228.
23. Wisman LA, Sahin G, Maingay M, Leanza G, Kirik D. Functional convergence of dopaminergic and cholinergic input is critical for hippocampus-dependent working memory. *Neurosci J* 2008; 28(31):7797-7807.doi:10. 1523/JNEUROSCI. 1885 -08.2008
24. Thenmozhi AJ, Dhivyabharathi M, Raja TRW, Manivasagam T, Essa MM. Tannoid principles of *Emblica officinalis* renovate cognitive deficits and attenuate amyloid pathologies against aluminum chloride induced rat model of Alzheimer's disease. *Nutr Neurosci* 2015; 19(6):269-278. doi.org/10.1179/14768 30515Y.0000000016
25. Li C, Long P, He M, Han F, Jiang W, Li Y, Wen X. *Phyllanthus emblica* Linn. fruit polyphenols improve

acute paradoxical sleep deprivation-induced cognitive impairment and anxiety via Nrf2 pathway. *J Funct Foods* 2023; 110:105884.

doi: [org/10.1016/j.jff.2023.105884](https://doi.org/10.1016/j.jff.2023.105884)

26. Margolis RL, Rauch CT, Wilson L. Mechanism of colchicine-dimer addition to microtubule ends: implications for the microtubule polymerization mechanism. *American Chemical Society* 1980; 19(24):5550-5557. doi: 0006-2960/80/0419-5550.
27. Osborn M, Weber K. Cytoplasmic microtubules in tissue culture cells appear to grow from an organizing structure towards the plasma membrane. *Proc Natl Acad Sci USA* 1976; 73(3):867-871.
28. Emerich DF and Walsh TJ. Cholinergic cell loss and cognitive impairments following intraventricular or intradentate injection of colchicine. *Brain Res* 1990; 517(1-2):157-167
29. Jiangbo N, Liyun Z. Effect of donepezil hydrochloride & aerobic exercise training on learning and memory and its mechanism of action in an Alzheimer's disease rat model. *Pak J Pharm Sci* 2018; 31(6): 2897-2901
30. Joy T, Rao MS, Madhyastha S, Pai K. Effect of N-Acetyl Cysteine on Intracerebroventricular Colchicine Induced Cognitive Deficits, Beta Amyloid Pathology, and Glial Cells. *Neurosci J* 2019; 1:7547382. doi:org/10.1155/2019/7547382
31. Sil S, Ghosh T, Ghosh R, Gupta P. Nitric oxide synthase inhibitor, aminoguanidine reduces intracerebroventricular colchicine induced neurodegeneration, memory impairments and changes of systemic immune responses in rats. *J Neuroimmunol* 2016; 303:51-61. doi: 10.1016/j.jneuroim.2016.12.007
32. Ashwlayan VD, Singh R. Reversal effect of *Phyllanthus emblica* (euphorbiaceae) rasayana on memory deficits in mice. *Int J App Pharm* 2011; 3(2):10-15.